

TECHNICAL DATA SHEET

PRO-SERIES ROUND FLANGE V-76 x 200mm

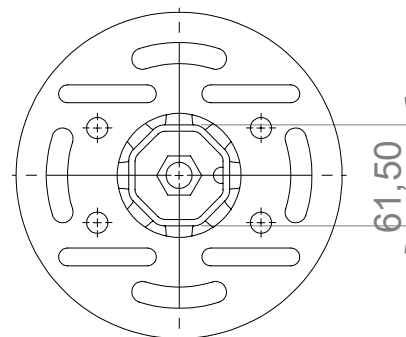

Art. no:	58221
Weight:	2,9 kg
Dimensions:	Pipe: 76,0 x 3,6 x 220 mm Flange: 8,0 x 200 mm
Materials:	Steel Type Pipe: S235 Steel Type Flange: S355 Surface treatment: Galvanized according to DIN EN ISO 1461
Installation:	Electric Ground Screw Driving Machine (Art.No: 12001) Pneumatic Ground Screw Driving Machine (Art.No: 12005) Hydraulic Ground Screw Driving Machine (Art.No: 12090)
Use:	Construction e.g. porches, garden rooms and modular homes.
Fixation:	M12 Bolts

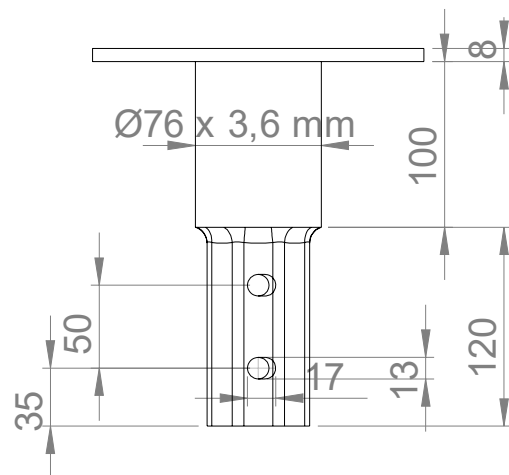
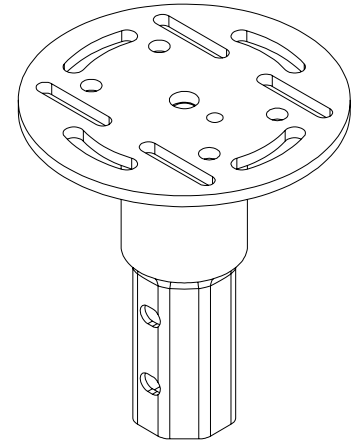

Drawing description	PRO-SERIES ROUND FLANGE V-76 x 200mm	
Date	Signed	Sheet number
12/2018	DVDE	1 of 1
Drawing number	Format	Document status
58221-V1	A4	DEF.

Products to combine:

- 58201 – V-76 GROUND SCREW 1200mm
- 58202 – V-76 GROUND SCREW 2100mm
- 58211 – V-76 EXTENSION 500mm
- 58212 – V-76 EXTENSION 1000mm
- 58213 – V-76 EXTENSION 1500mm
- 58214 – V-76 EXTENSION 2000mm

FIRST BASE GROUND SCREWS
Patersweg 2, 5406 XJ
Uden, Holland.

info@firstbasegroundscrews.com
www.firstbasegroundscrews.com
0031 413 432 052