

TECHNICAL DATA SHEET

PRO-SERIES GROUND SCREW Ø76 x 1000mm



Art. no:	31041
Weight:	7,60 kg
Dimensions:	Pipe: 76,1 x 3,0 x 1000 mm Flange: 8,0 x 200 mm
Materials:	Steel Type Pipe: S235 Steel Type Flange: S355 Surface treatment: Galvanized according to DIN EN ISO 1461
Installation:	Electric Ground Screw Driving Machine (Art.No: 12001) Pneumatic Ground Screw Driving Machine (Art.No: 12005) Hydraulic Ground Screw Driving Machine (Art.No: 12090)
Use:	Light construction e.g. porches, garden rooms and modular homes.
Fixation:	M16 Bolts

Side view

Cross cut

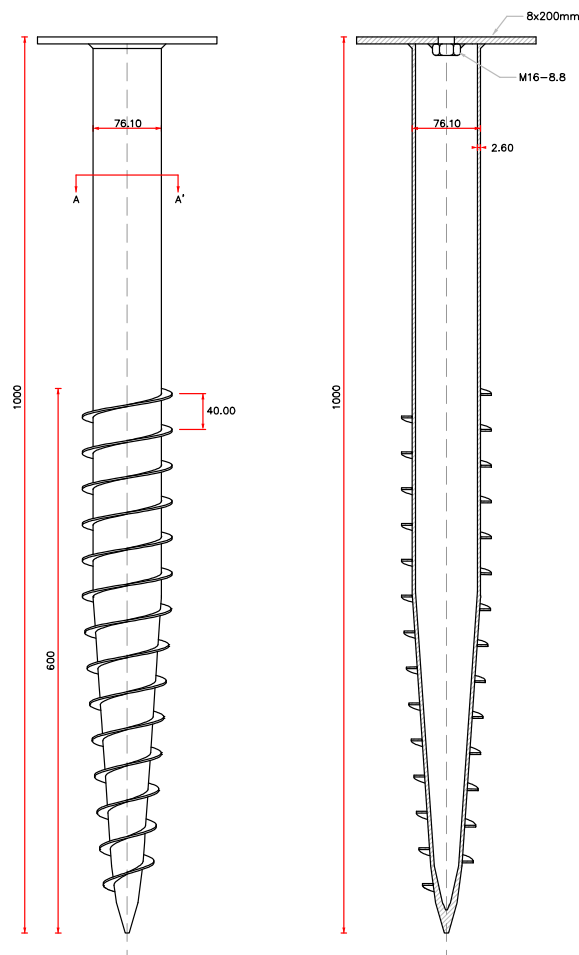

Top view flange

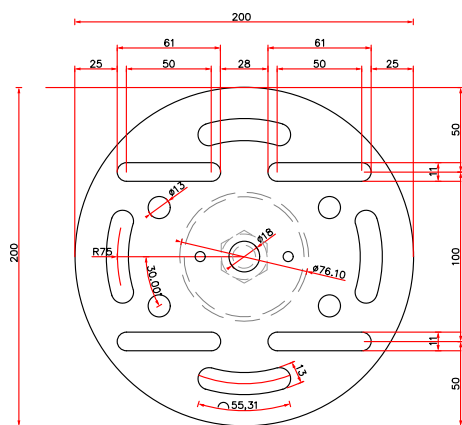

Cross cut pipe (A-A')

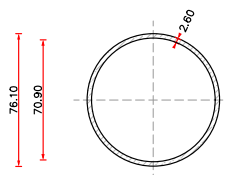

Drawing description	PRO-SERIES GROUND SCREW Ø76 x 1000mm	
Date	Signed	Sheet number
12/2018	DVDE	1 of 4
Drawing number	Format	Document status
31041-V1	A4	DEF.

Products to combine:

- 17021 – POLEHOLDER M20
- 17022 – L-BRACKET M16 80mm
- 17023 – L-BRACKET M16 160mm

FIRST BASE GROUND SCREWS
Patersweg 2, 5406 XJ
Uden, Holland.

info@firstbasegroundscrews.com
www.firstbasegroundscrews.com
0031 413 432 052

[Click here](#) for the FIRST BASE Load Capacity Chart